

## DRIVER AND MAINTENANCE OPERATIONS

### TD steering system

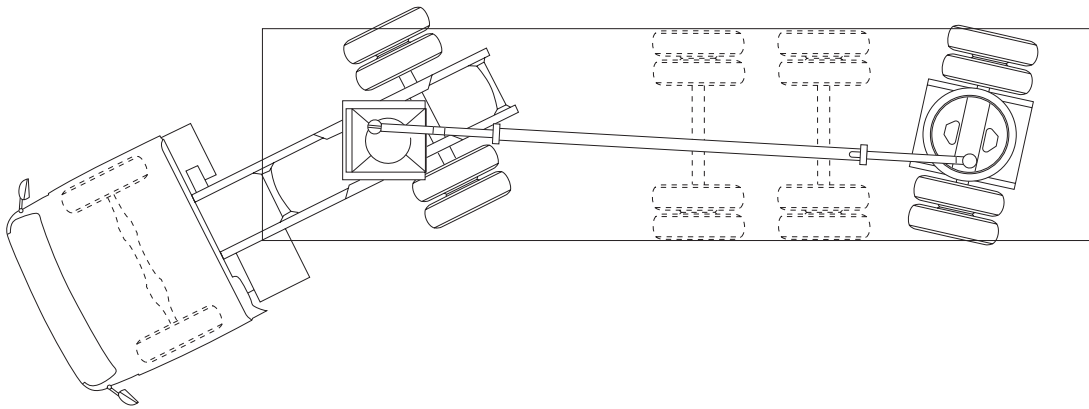

The specifications in this documentation have been drawn up with great care. We cannot however accept any liability whatsoever for any errors.

© Copyright Tridec b.v. Son Holland.

No part of this publication may be reproduced and/or published by printing, photocopying, on microfilm or in any manner whatsoever without the prior written consent of Tridec b.v.

**CONTENTS**

<b>1. SAFETY</b>	<b>3</b>
<b>2. GENERAL</b>	<b>5</b>
2.1 Steering system description	5
2.2 Type designation	6
2.3 Technical data	7
2.3.1 Oil and lubricant specification	7
2.3.2 Tightening torques	8
2.3.3 Test torques	9
2.3.4 Inspection and adjustment data	9
2.3.5 Special tools	10
<b>3. DRIVING</b>	<b>11</b>
3.1 Coupling and uncoupling	11
3.2 Driving	12
<b>4. MAINTENANCE</b>	<b>13</b>
4.1 Maintenance points	13
4.1.1 Maintenance interval	13
4.1.2 Coupling platform	14
4.1.3 Bogie	14
4.1.4 Pull/push rod	15
4.2 Testing bolts	16
4.2.1 General	16
4.2.2 Coupling platform	16
4.2.3 Bogie	18
4.2.4 Pull/push rod	18
4.3 Lubricating points	19
4.3.1 General	19
4.3.2 Coupling platform lubricating points	20
4.3.3 Bogie lubricating points	21
4.4 Cleaning	22
<b>5. FAULTS</b>	<b>23</b>
5.1 Mechanical fault-finding table	23
<b>6. DISASSEMBLY AND ASSEMBLY</b>	<b>25</b>
6.1 Pull/push rod	25
6.2 Pull/push rod bearing	29
6.3 Steering wedge rubbers	31
6.4 Coupling platform	32
6.5 Bogie turntable	33
6.6 Bolted cross member of bogie	34
<b>7. ALIGNING</b>	<b>35</b>
7.1 Aligning steering system	35

<b>8. PARTS LIST</b>	<b>37</b>
8.1 Ordering parts	37
8.2 Coupling platform, cast version	38
8.3 Coupling platform, welded version	40
8.4 Pull/push rod	42
8.5 Bogie with bolted bearing journal	44
8.6 Bogie with welded bearing journal	46
8.7 Bogie with bolted cross member	48

## 1. SAFETY



Where this symbol is shown, information is given to prevent injury or a life-threatening situation.



Where this symbol is shown, information is given to prevent damage to the steering system.

### Driving with the steering system

- The steering characteristic of a steered semi-trailer differs from that of a non-steered semi-trailer.
- Remember that when cornering a steered semi-trailer will show different steering behaviour from a non-steered semi-trailer.

### Maintenance operations on the steering system

- The steering system is a safety-critical system. Perform the maintenance operations carefully. Shoddy workmanship could cause damage and/or an accident.
- Chock the wheels of the semi-trailer safely when working underneath it.
- Place solid blocks under the semi-trailer when carrying out work involving the removal of wheels.
- When removing heavy components, use hoisting apparatus or support them in a safe manner.
- Avoid unnecessary contact with oil and lubricants. Apply protective cream to unprotected parts of your body.



## 2. GENERAL

### 2.1 STEERING SYSTEM DESCRIPTION

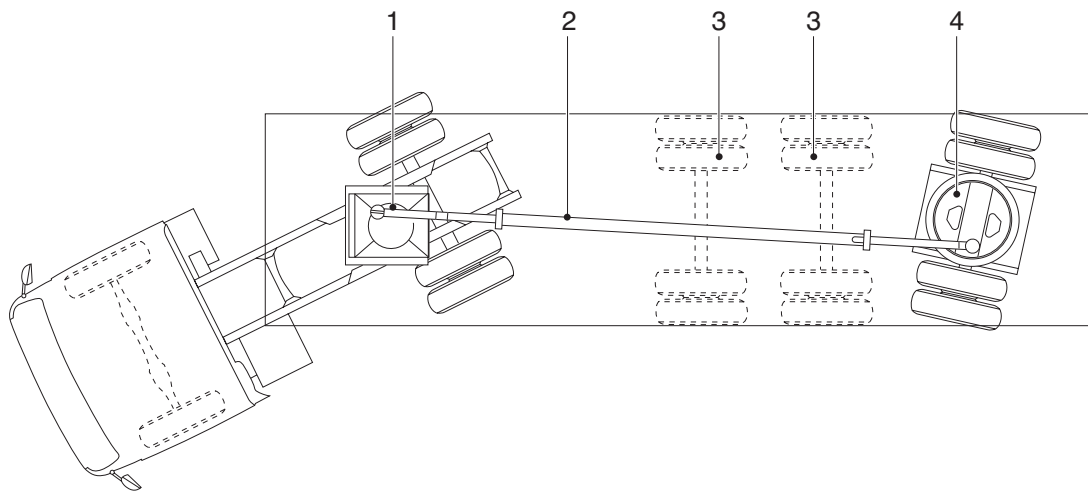

270 042

The type designation TD stands (in Dutch) for pull/push rod with a single steered axle. The semi-trailer can also be provided with up to 2 rigid axles (3).

While the tractor is being steered in, the steering motion is transmitted to the coupling platform (1) via a wedge that drops into the fifth wheel. A pull/push rod (2) connects the steered axle bogie (4) to the coupling platform (1).

If there are several axles, the rearmost one is always the steered one.

Besides providing greatly improved semi-trailer manoeuvrability, the steering system has a favourable effect on maintenance costs, due to longer tyre life, lower fuel consumption and less wear on the axle mounting.

**2.2 TYPE DESIGNATION**

S	E	1510 S	xxxxx	L	xxxxxxx	
S						Steering system
	E T D					Single-axle semi-trailer Two-axle semi-trailer Three-axle semi-trailer
		15 18 10				15-ton coupling pressure 18-ton coupling pressure 10-ton axle load per steered axle
			S T			With 1200 mm turntable With 1100 mm turntable
				xxxxx		Type: see identity card
				L Z G C		Welded Self-supporting body Fitted with bolts Cast
					xxxxxxx	Serial number

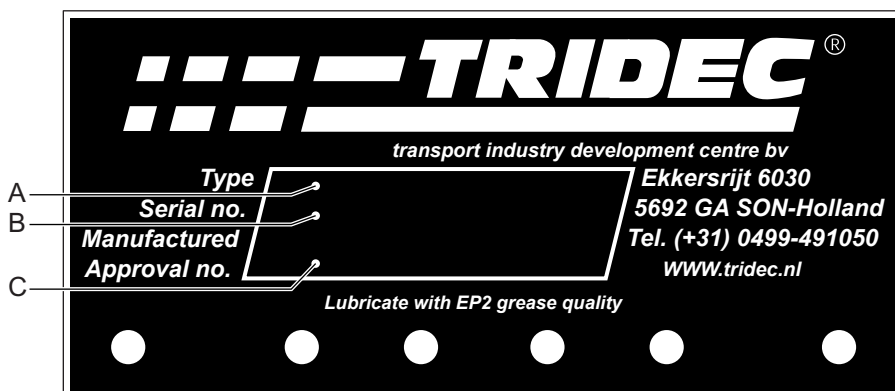

270 095

- A Type
- B Serial number\*
- C Ministry of Transport approval number

\* When ordering parts and/or for warranty claims, quote the serial number.



## 2.3 TECHNICAL DATA

### 2.3.1 Oil and lubricant specification



In order to comply with the warranty conditions and assure the life of the steering system, only the specified oil and lubricant must be used.

Tridec is not responsible for damage resulting from the use of oil and lubricants that do not meet the stipulated specifications and/or failure to observe the proper maintenance interval.

Grease of NLGI class 0 or 00 must not be used

#### Lubricants

FINA CERAN M grease is applied to Tridec steering systems in the factory. This is a multi-purpose grease for lubricating under high loads.

Only lubricate the steering systems using grease that meets at least the specifications given below.

METHOD	CHARACTERISTICS	
	NLGI class	1
ASTM D 217	Penetration, 0.1 mm	336
ASTM D 445	Viscosity of basis oil, mm <sup>2</sup> /s	650
ASTM D 2265	Pour point, °C	> 300
ASTM D 2509	Timken OK load, lbs	70
DIN 51350-4	4-ball weld, kg	480

#### Hydraulic oil

Total Equivis ZS22 oil is applied to Tridec steering systems in the factory. This is a mineral hydraulic oil with a low zinc content and a very high viscosity index, to which anti-wear, anti-oxidant, anti-corrosion and anti-foam dopes have been added. This oil is very well suited for heavy and varied conditions.

ISO	6743/4 – HV category
CETOP	RP 91 HV category
DIN 51524	part 3 – HVLP category
DENISON	HF-1, HF-2, HF-0
VICKERS	M-2950-S and I-286-S
CINCINNATI-MILACRON	P68, P69, P70
AFNOR	48-603 HV and 48-691
US Steel	136, 127

Only lubricate the steering systems using hydraulic oil that meets at least the specifications given below.

ASTM METHODS	CHARACTERISTICS	ISO 22
D 4052	Density at 20 °C, kg/dm <sup>3</sup>	0.86
D 445	Viscosity at 40 °C, mm <sup>2</sup> /s	22.24
D 445	Viscosity at 100 °C, mm <sup>2</sup> /s	4.91
D 2270	Viscosity index	152
D 97	Pour point, °C	-48
D 92	Flash point, °C	184
D 664	TAN, mg KOH/g	0.5

The following types of oil are permitted for use in Tridec systems

FINA	Hydran TSX 22
ELF	Hydrelf 22
SHELL	Tellus T 22
TEXACO	Rando HDZ 22
BP	Energol SHF-HF 22
ESSO	Univis N22
AGIP	Amica 22

Mixing different types of oil is not permitted

### 2.3.2 Tightening torques

Apply the following tightening torques when fitting the parts mentioned.

Coupling platform, cast version

- M14 nuts on 2" and 3½" Eurohitch king pin 190 Nm
- M20 nuts on 2" and 3½" Jost king pin 400 Nm
- M16 x 80 (10.9) attachment bolts 225 Nm
- M12 x 30 attachment bolts, steering wedge 80 Nm\*

Coupling platform, welded version

- M14 nuts on 2" and 3½" Eurohitch king pin 190 Nm
- M20 nuts on 2" and 3½" Jost king pin 400 Nm
- M16 x 80 (10.9) attachment bolts (socket head) 300 Nm
- M16 x 55 (8.8) attachment bolts 200 Nm
- M12 x 30 attachment bolts, steering wedge 80 Nm\*
- M20 x 70 (10.9) attachment bolts, bearing journal 520 Nm

Pull/push rod

- M16 (8.8) central bolt, pull/push rod bearing 120 Nm\*\*
- M20 attachment bolts 400 Nm

Bogies

- M16 hexagonal attachment bolts on turntable 200 Nm
- M16 Tridec attachment bolts on turntable 350 Nm\*\*\*

\* Provided with Loctite 270 or equivalent.

\*\* Provided with Loctite 243 or equivalent.

\*\*\* Use only new bolts and corresponding nuts

**2.3.3 Test torques**

Test the screw-thread fastening by applying the following torques.

Coupling platform, cast version

- M14 nuts on 2" and 3½" Eurohitch king pin 170 Nm
- M20 nuts on 2" and 3½" Jost king pin 360 Nm
- M16 x 80 (10.9) attachment bolts 205 Nm
- M12 x 30 attachment bolts, steering wedge 72 Nm

Coupling platform, welded version

- M14 nuts on 2" and 3½" Eurohitch king pin 170 Nm
- M20 nuts on 2" and 3½" Jost king pin 360 Nm
- M16 x 80 (10.9) attachment bolts (socket head) 270 Nm
- M16 x 55 (8.8) attachment bolts 180 Nm
- M12 x 30 attachment bolts, steering wedge 72 Nm
- M20 x 70 (10.9) attachment bolts, bearing journal 470 Nm

Pull/push rod

- M16 (8.8) central bolt, pull/push rod bearing 108 Nm
- M20 attachment bolts 360 Nm

Bogies

- M16 attachment bolts on turntable 180 Nm
- M16 Tridec attachment bolts on turntable 315 Nm

**2.3.4 Inspection and adjustment data**

Coupling platform

Maximum permissible play on the turntable 3 mm

Bogie

Maximum permissible play on the turntable 3 mm

Pull/push rod

Maximum permissible radial play (A) 1 mm

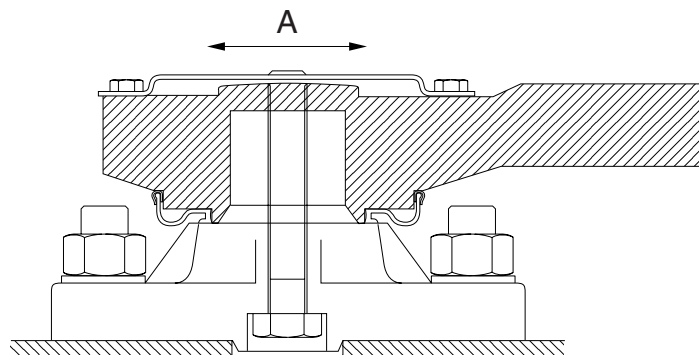

270089

**2.3.5 Special tools**

Special tool for assembling and disassembling the bearing of the pull/push rod.  
 Order number: 310422.

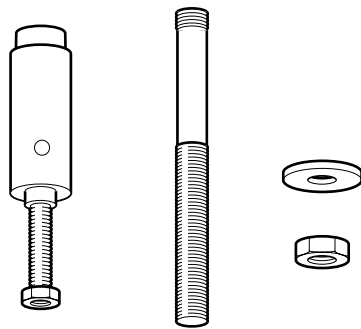

270 011

Special tool for fitting the seal ring on the pull/push rod bearing.  
 You have to make this tool yourself. See the drawing for the dimensions

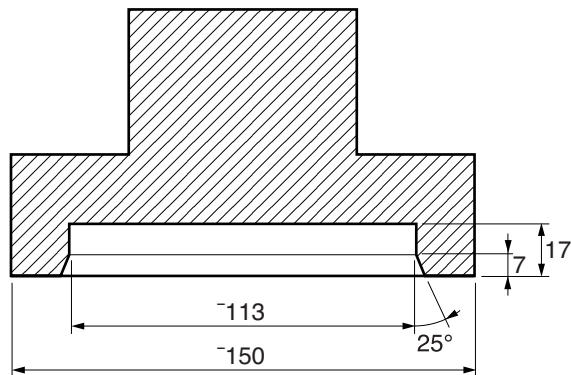

270023

### 3. DRIVING

#### 3.1 COUPLING AND UNCOUPLING

##### Coupling

1. Make sure the tractor and semi-trailer are at the correct coupling height. The semi-trailer is not allowed to be tilted when coupling.



This may cause the semi-trailer to move, which should be avoided.

2. Drive the tractor in a straight line under the semi-trailer. The semi-trailer must not be coupled at an angle.



This may result in out-of-trueness or damage to the system.

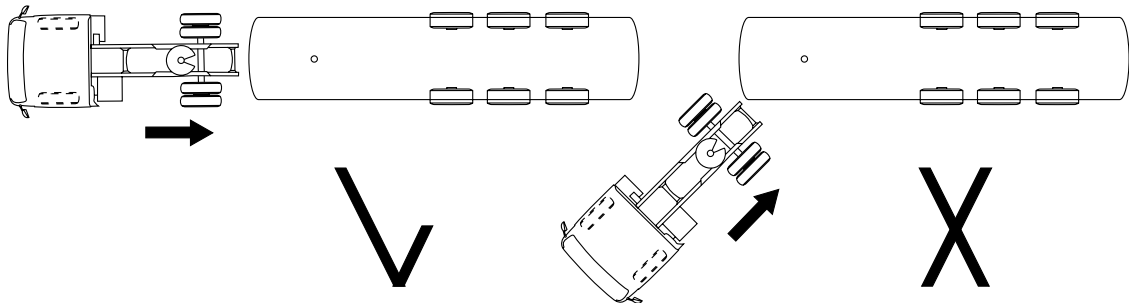

270019

##### Uncoupling

1. Make sure the combination is in a straight line.
2. Make sure the combination is on a flat surface.
3. Extend the semi-trailer legs until the semi-trailer stays at the same height during uncoupling.
4. Drive the vehicle in a straight line from under the semi-trailer. The semi-trailer must not be uncoupled at an angle.

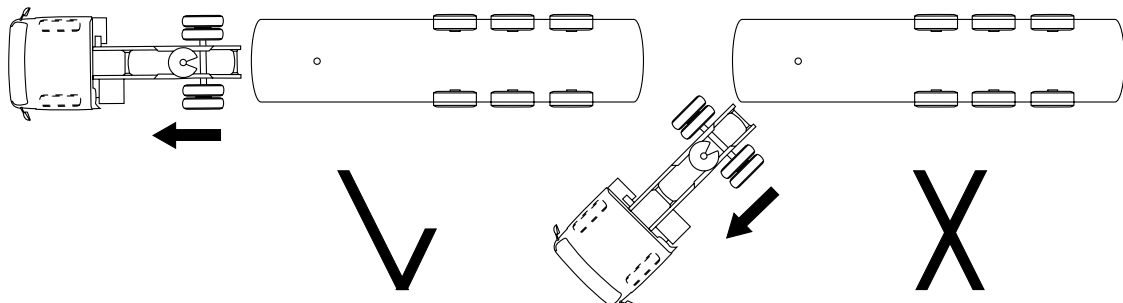

270021

**3.2 DRIVING**



The steering characteristic of a steered semi-trailer differs from that of a non-steered semi-trailer.

Remember that the rear of the semi-trailer swings out on a bend.

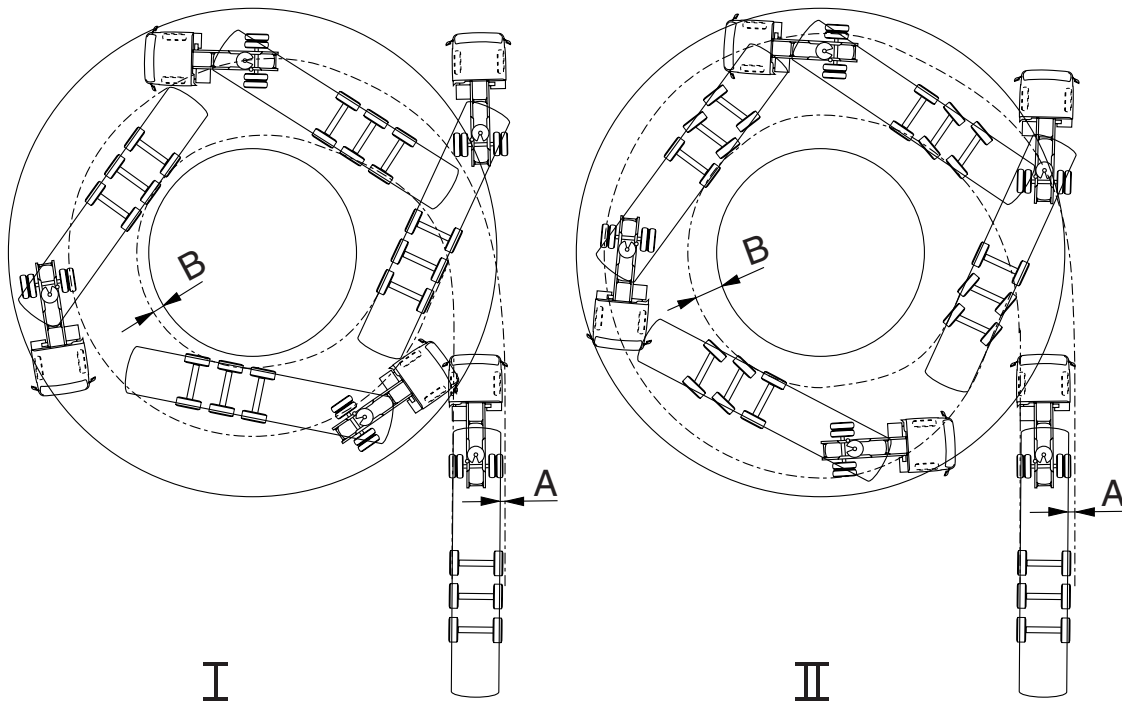

270024

Situation I: Steering circle of non-steered semi-trailer

Situation II: Steering circle of steered semi-trailer

When entering a bend (point A) a steered semi-trailer will swing out further than a non-steered semi-trailer.

The radius of the inside bend (point B) is greater on a steered semi-trailer than on a non-steered semi-trailer. This makes it possible to manoeuvre through narrower streets.



When on a roadway that makes a sharp angle of inclination, such as a loading bay, take care that the tractor's rear overhang or the trailer's headboard does not touch or strain any parts of the steering gear. Straining the steering gear can cause damage to the steering system.

## 4. MAINTENANCE

### 4.1 MAINTENANCE POINTS

#### 4.1.1 Maintenance interval

##### **First service**

After the first 10,000 km or 2 months after the vehicle is first used, the following operations must be carried out.

- Test the bolts in the following parts. For the specified test torques, see “Technical data”.
- King pin
- Coupling platform
- Pull/push rod
- Bogie

##### **Service inspection**

Every 50,000 km or 6 months the following operations must be carried out.

- Check the turntables of the coupling platform and bogies for play.
- Apply a test torque to the bolts in the turntables.
- Check the pull/push rod bearings for play and the condition of the gaiter.
- Apply a test torque to the attachment bolts in the pull/push rod.
- Check the free movement of the steering wedge.
- Check the steering wedge rubbers for wear.
- Check the glide strips on the mounting brackets of the pull/push rod for wear.
- If a manual lubrication system is fitted, apply new grease to all lubricating points.
- If an automatic central lubrication system is fitted, check that it is working properly. Fill the grease reservoir.

#### 4.1.2 Coupling platform

1. Check the coupling platform for play.
  - Insert a rod between the king pin and the steering wedge.

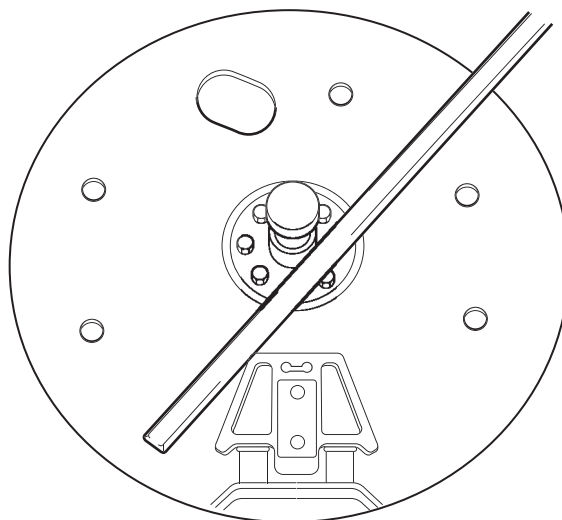

270 039

- Apply force to the rod. Check whether the coupling platform turntable shows any play. For the maximum permissible play, see “Technical data”.
  - Replace the coupling platform if play is excessive.
2. Check the free movement of the steering wedge.
    - Push steering wedge back.
    - Release the steering wedge. After being released, the steering wedge should easily return to the neutral position.
  3. Check the steering wedge rubbers for drying-out and cracking. Replace the rubbers if necessary.

#### 4.1.3 Bogie

1. Check the turntables of the bogies for play.
  - Insert a crowbar into the turntable.

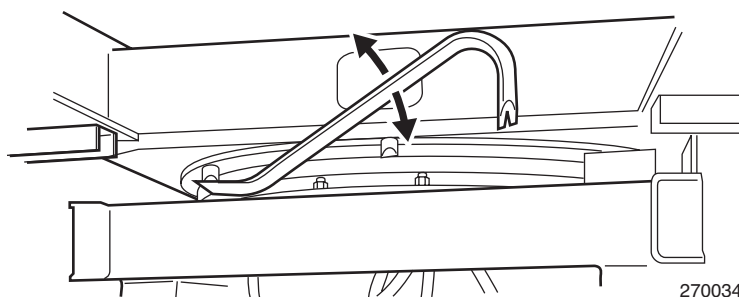

270034

- Move the crowbar up and down. Check whether the bearing shows play.
- For the maximum permissible play, see “Technical data”.
- Replace the turntable if play is excessive.



#### 4.1.4 Pull/push rod

1. Check the gaiter of the bearings for wear and damage. Replace the gaiter if signs of wear and/or damage are found.
2. Check the pull/push rod bearings for radial play.
  - Insert a rod between the king pin and the steering wedge.

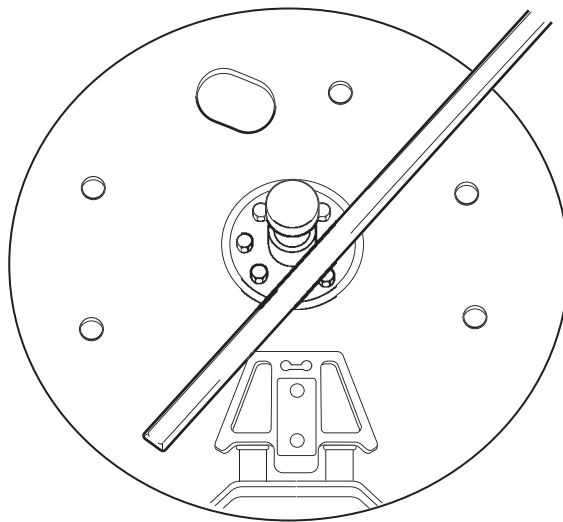

270 039

- Apply force to the rod. Check whether the bearing shows radial play. For the maximum permissible play, see “Technical data”.
- Replace the bearing if play is greater than this.

## 4.2 TESTING BOLTS

### 4.2.1 General

Check that the screw-thread connection is properly secure by applying a test torque to it.

1. Place an indicating torque wrench on the bolt head.
2. Apply the test torque. The bolt must not turn when this is done.
3. If the bolt turns, remove the connection and check the bolt and nut.  
If specified, apply locking compound to the bolt and tighten it to the specified tightening torque.  
See "Technical data".



Replace any self-locking nuts that have rotated.

If one or more bolt connections is loose it is advisable to replace all the bolts in the bolt connection concerned.

### 4.2.2 Coupling platform

#### Cast version

1. Check the tightening torque of the bolts (A) that are located on the underside of the coupling platform.
2. Check the tightening torque of the bolts (B) that are located on the side of the coupling platform.

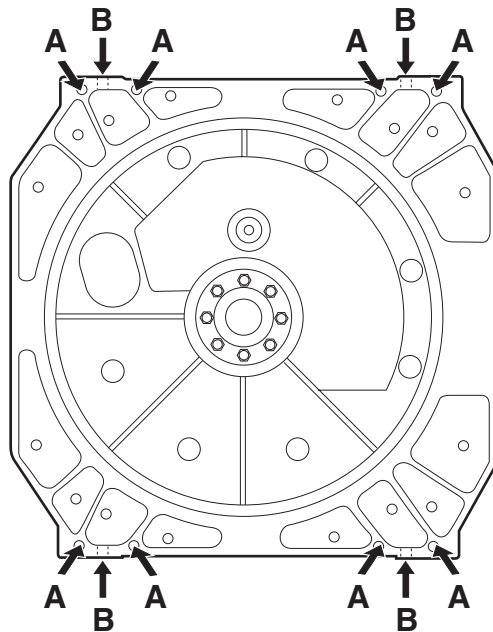

270 043

**Welded version**

Not all bolts on the coupling platform are easily accessible.

1. Lift the rear of the semi-trailer until the wheels are off the ground. Support the semi-trailer in a safe manner.
2. Insert a rod between the king pin and the steering wedge. The coupling platform can be rotated using the rod.

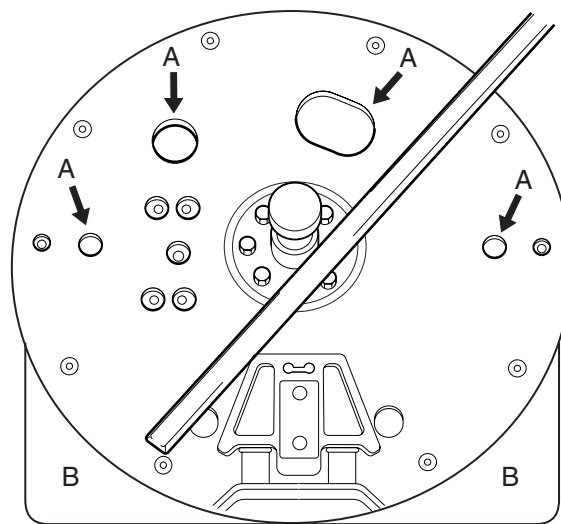

270008

3. Check the accessible bolts through openings A. Rotate the coupling platform and check the remaining accessible bolts.
4. The bolts that are not accessible through openings A are accessible through opening B on the side of the turning platform.
5. Check the bearing-journal bolts through openings A.

#### 4.2.3 Bogie

1. Check the tightening torque of the bolts in the turntable.
2. If a bolted bearing journal is fitted, check the tightening torque of the bolts in the bearing journal.
3. If a bolted cross beam is fitted, check the tightening torque of the bolts in the cross beam.

#### 4.2.4 Pull/push rod

1. Check the tightening torque of the bolts in the coupling pieces.

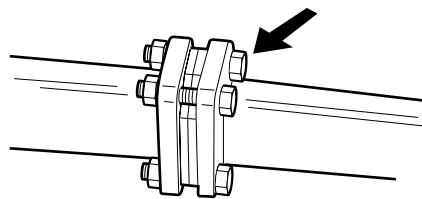

270031

2. Check the tightening torque of the locking bolt in the pull/push rod bearings

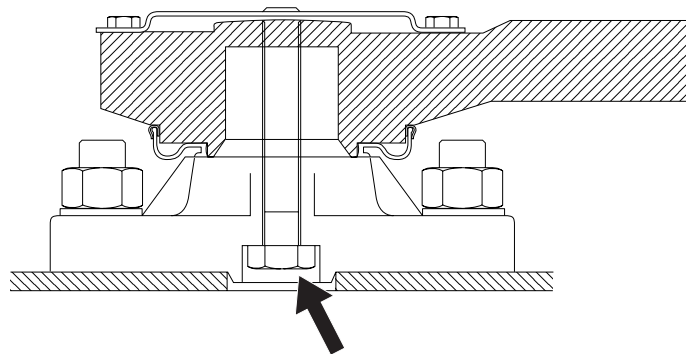

270017

### 4.3 LUBRICATING POINTS

#### 4.3.1 General

##### Manual lubricating

1. The semi-trailer must be unladen:
2. Clean the lubricating nipples and the surrounding area.
3. Remove the caps from the nipples.
4. Apply the specified grease to the lubricating nipples (see "Technical data") until a new grease collar forms at the point to be lubricated.



The lubricating points must be amply lubricated so that a grease collar sealing the bearing forms around the entire circumference of the bearing at the point of the seal .

5. Fit the caps to the nipples.
6. Take a test drive, steering in to the left and right to the maximum extent.
7. Remove the caps from the nipples.
8. Lubricate the lubricating points again.
9. Fit the caps to the lubricating nipples.

##### Automatic lubrication system

1. Fill the reservoir with the specified grease. See "Technical data".
2. Switch on the automatic lubrication system. Check that every lubricating point is greased.



The lubricating points must be amply lubricated so that a grease collar sealing the bearing forms around the lubricating point.

3. Check the lubrication pipes for damage and kinks.

### 4.3.2 Coupling platform lubricating points

#### Cast version

The coupling platform has one lubrication block with four lubrication connections.

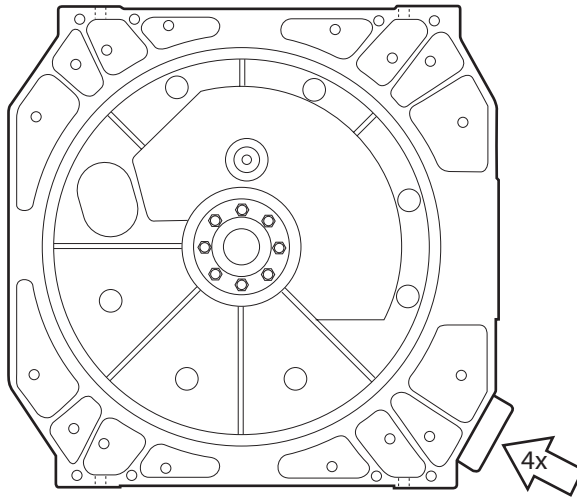

270 044

#### Welded version

The coupling platform has one lubrication block with four lubrication connections.

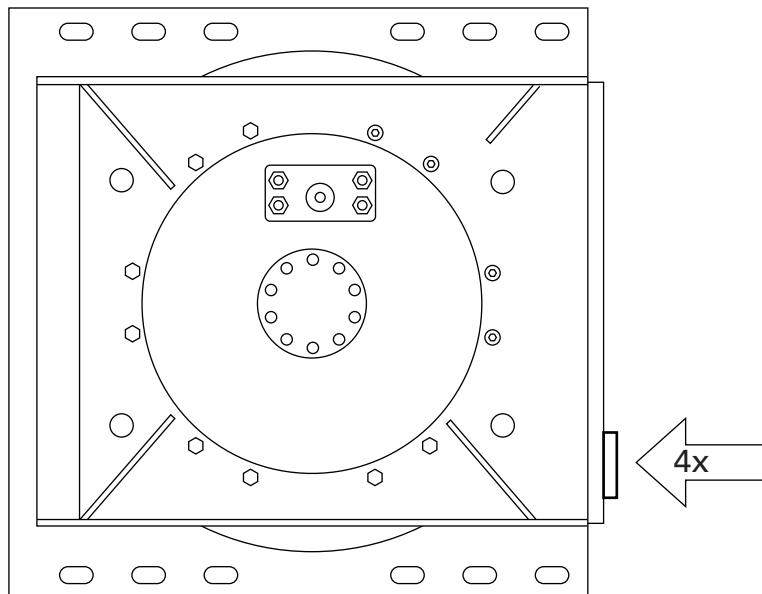

270020

### 4.3.3 Bogie lubricating points

#### Version with bolted bearing journal.

The bogie has one lubrication block with six lubrication connections.

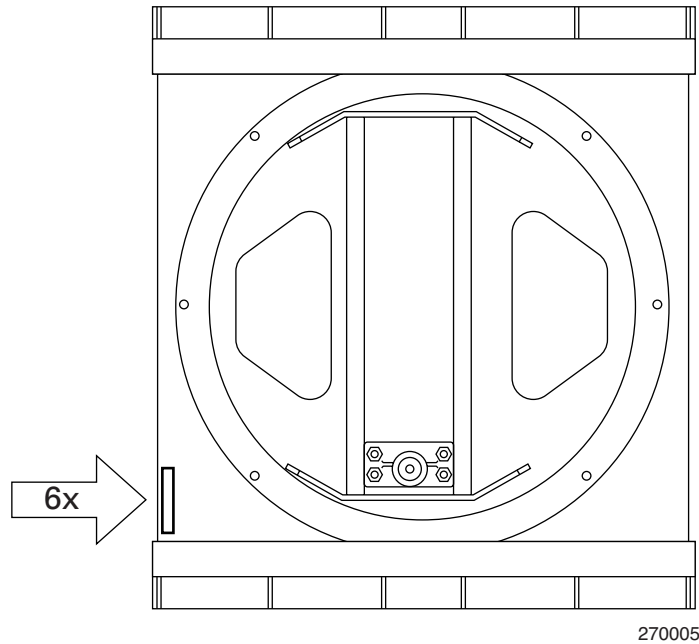

#### Version with welded bearing journal.

The bogie has one lubrication block with six lubrication connections.

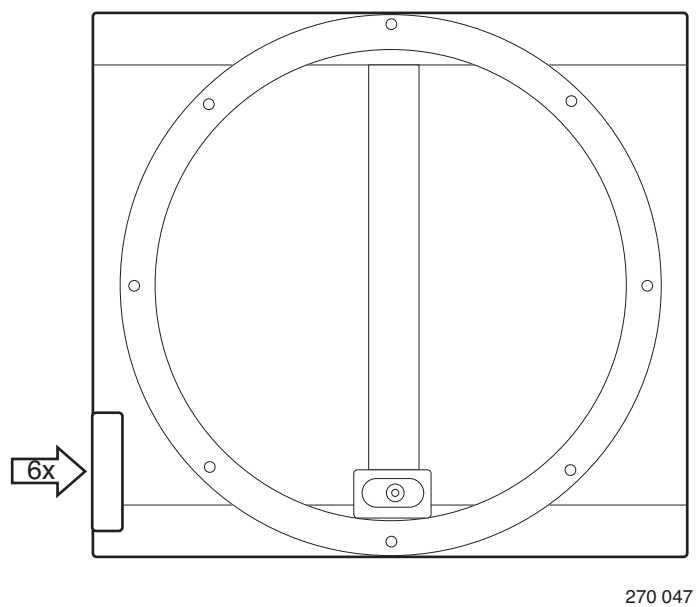

#### **4.4 CLEANING**

If the semi-trailer is cleaned with a high-pressure sprayer, bear the following points in mind:

- Do not direct the jet at turntables, bearings or bearing seals.
- Do not direct the jet at the steering ball joints.
- Do not direct the jet at cylinder gaskets.
- Do not direct the jet at electrical components or connectors.
- Lubricate the lubricating points after cleaning.



**5. FAULTS**

**5.1 MECHANICAL FAULT-FINDING TABLE**

<b>The semi-trailer runs alternately left and right out of line</b>	
<b>Possible cause</b>	<b>Solution</b>
Steering wedge is stuck and does not connect	Disassemble the steering wedge. Clean the steering wedge.
Worn steering wedge rubbers	Replace the steering wedge rubbers.
Excessive play in bearings in turntables, coupling platform, pull/push rod.	Check the components for excessive play. If excessive play is found, replace the bearings.
Loose bolts on axle bracket, coupling platform, turntable or pull/push rod bearings.	Apply a test torque to the bolts specified.

<b>The semi-trailer deviates from the tractor's path</b>	
<b>Possible cause</b>	<b>Solution</b>
Incorrect alignment of the pull/push rod	Check the alignment of the pull/push rod. Correct the alignment.
Incorrect alignment of the tractor	Check the alignment of the tractor. Correct the alignment.
Fifth wheel incorrectly positioned	Check the position of the fifth wheel. Check the position of the fifth wheel.



## 6. DISASSEMBLY AND ASSEMBLY

### 6.1 PULL/PUSH ROD

#### Removing pull/push rod

1. Remove the bolts (2) from the pull/push rod coupling pieces. Keep the adjusting plates (1) together.
2. Remove the rod guides if necessary. Remove the middle part of the pull/push rod from under the semi-trailer.

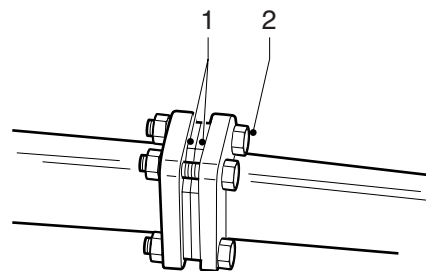

270 030

3. Remove the central bolt (3) of the bearing.

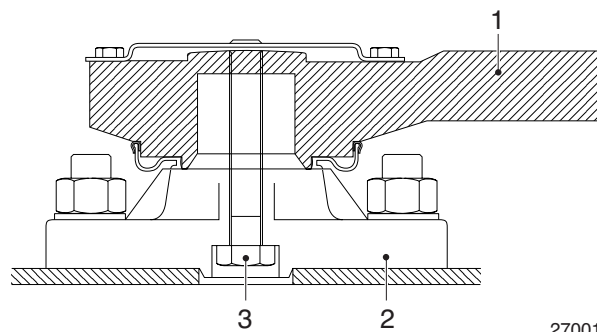

270016

4. Fit the stud (1) (special tool: see “Technical data”), with the short wire end in the bearing.
5. Unscrew the bolt (3) of the bearing extractor (2) (special tool: see “Technical data”). Fit the bearing extractor (2) into the threaded hole of the bearing journal.

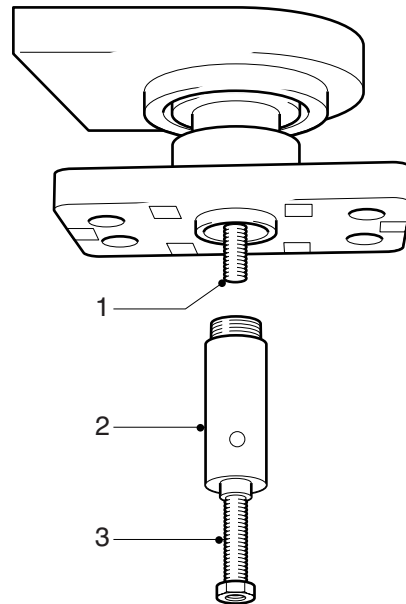

270014

6. Screw the bolt (3) of the bearing extractor (2) in until the steering rod comes loose from the bearing journal.
7. Remove the pull/push rod from under the vehicle.
8. Remove the other pull/push rod part in the same way.

**Fitting pull/push rod**

1. Apply a little anti-seize compound to the bearing journal.
2. Place the bearing on the bearing journal.
3. Fit the stud (3) (special tool: see “Technical data”), with the short wire end in the bearing.
4. Fit the washer (1) and the nut (2) onto the stud.

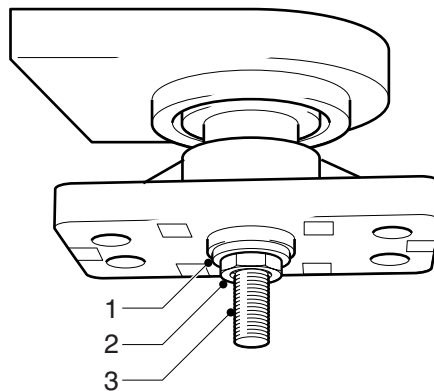

270013

5. Tighten the nut until the bearing (1) touches the bearing journal (2).

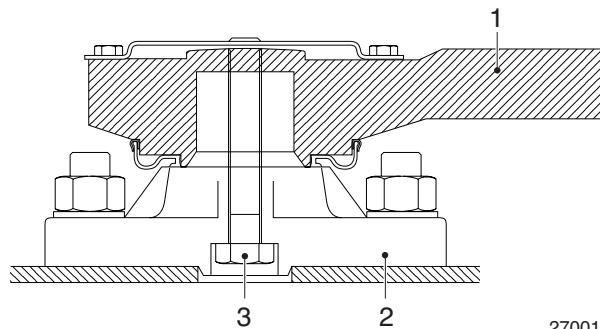

270016

6. Fit the central bolt (3). Tighten the bolt to the specified tightening torque. See “Technical data”.
7. Fit the other pull/push rod part in the same way.

8. Fit the adapter of the pull/push rod. Fit the original set of adjusting plates (1). Fit the bolts (2); the bolt heads must point towards the axles of the semi-trailer. Tighten the bolts to the specified tightening torque. See "Technical data".

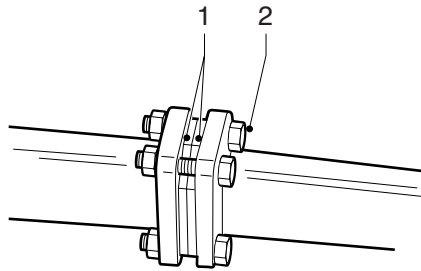

270 030

9. Check the alignment if there is a new pull/push rod part. If necessary, change the number of adjusting plates.
10. Fit the rod guides.

## 6.2 PULL/PUSH ROD BEARING

### Disassembling pull/push rod bearing

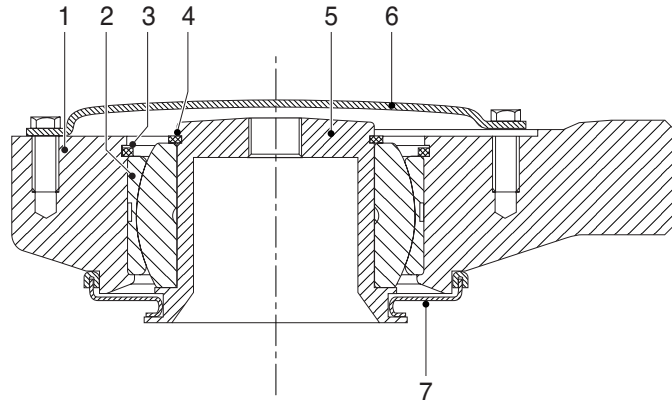

270 007

1. Remove the relevant pull/push rod part from the semi-trailer.
2. Remove the cover (6).
3. Remove the grease under the lid.
4. Remove the circlip (4).
5. Remove the seal (7) from the pull/push rod (1).
6. Press the bearing bush (5) out of the bearing (2).
7. Remove the circlip (3).
8. Press the bearing (2) out of the pull/push rod (1).

### Assembling pull/push rod bearing

1. Press the new bearing (2) as far as the stop in the pull/push rod (1).
2. Fit the circlip (3).
3. Fit the seal ring (7) onto the bearing bush (5).
4. Apply some grease to the outside of the bearing bush (5).
5. Press the bearing bush (5) as far as the stop in the bearing (2).
6. Fit the circlip (4).

7. Fit the seal ring (7), preferably with the special tool (A). See “Technical data”.

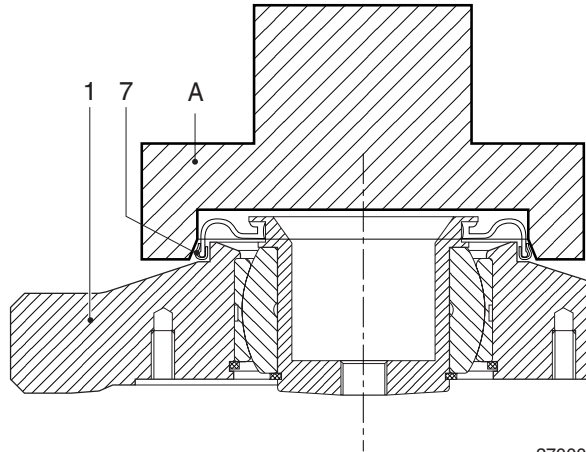

270006

If the special tool is not available, the seal ring (7) can also be fitted carefully onto the pull/push rod with a punch (B)

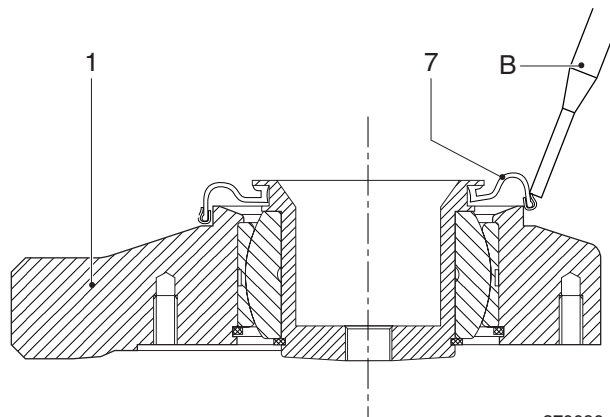

270090

8. Remove the socket head screw from side of the pull/push rod. Fit a lubricating nipple into the opening of the socket head screw.

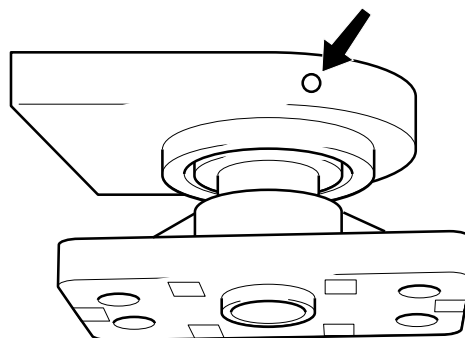

270015

9. Apply the specified grease to the bearing via the lubricating nipple (see “Technical data”) until the grease comes out at the top and bottom of the bearing.
10. Remove the lubricating nipple and fit the socket head screw.
11. Apply plenty of the specified grease to the top of the bearing.
12. Put a new gasket in the cover (6) and attach the cover.



### 6.3 STEERING WEDGE RUBBERS

#### Removing steering wedge rubbers

1. Remove the attachment bolts (3). Collect the lock plate (2) and the steering wedge (1).

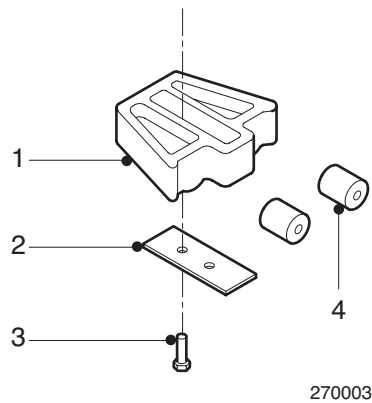

2. Remove the steering wedge rubbers (4).

#### Fitting steering wedge rubbers

1. Clean the steering wedge (1) and the alignment surfaces of the steering wedge rubbers (4).
2. Fit new steering wedge rubbers (4).
3. Apply locking compound to the attachment bolts (3). See "Technical data".
4. Check whether the steering wedge is clean and grease-free.
5. Check whether the steering wedge can move freely
6. Fit the steering wedge (1) and the lock plate (2).
7. Tighten the bolts (3) to the specified tightening torque. See "Technical data".
8. Check the free movement of the steering wedge (1).

## **6.4 COUPLING PLATFORM**

### **Removing cast coupling platform**

1. Remove the pull/push rod from the coupling platform.
2. Remove the lubrication pipes from centralised lubrication.
3. Support the coupling platform.
4. Remove the attachment bolts from the coupling platform. Take the coupling platform vertically off the chassis.

### **Fitting cast coupling platform**

1. Fit the coupling platform vertically onto the chassis. Tighten the attachment bolts to the specified tightening torque. See "Technical data".
2. Fit the lubrication pipes into centralised lubrication.
3. Grease the turntable until a grease collar forms. Turn the turntable while greasing.
4. Fit the pull/push rod.

### **Removing turntable from welded coupling platform**

1. Remove the pull/push rod from the coupling platform.
2. Remove the lubrication pipes.
3. Support the turntable plate.
4. Remove the attachment bolts from the turntable plate. Remove the turntable plate from the turntable.
5. Support the turntable.
6. Remove the attachment bolts from the turntable. Remove the turntable from the coupling platform.

### **Fitting turntable of welded coupling platform**

1. Fit the turntable onto the coupling platform. Tighten the attachment bolts to the specified tightening torque. See "Technical data".

**Note:**

Make sure that the turntable plate is mounted precisely in the centre of the coupling platform.

2. Fit the turntable plate onto the turntable. Tighten the attachment bolts to the specified tightening torque. See "Technical data".
3. Fit the lubrication pipes.
4. Grease the turntable until a grease collar forms. Turn the turntable while greasing.
5. Fit the pull/push rod.

## **6.5 BOGIE TURNTABLE**

### **Removing bogie turntable**

1. Remove the pull/push rod from the bogie.
2. Remove the lubrication pipes.
3. Support the bogie against tilting.
4. Where bolts with spacing bushes are used, mark the point where the bolt heads and the spacing bushes are located.
5. Remove the attachment bolts from the turntable.
6. Lift the semi-trailer and support it in a safe manner.
7. Remove the turntable.

### **Fit bogie turntable**

1. Fit the turntable with the specified bolts, spacing bushes and new self-locking nuts. Fit the bolts and spacing bushes in the manner marked.
2. Tighten the attachment bolts evenly. Then tighten the attachment bolts to the specified tightening torque. See "Technical data".
3. Fit the lubrication pipes.
4. Grease the turntable until a grease collar forms. Turn the turntable while greasing.
5. Fit the pull/push rod.

## **6.6 BOLTED CROSS MEMBER OF BOGIE**

### **Removing bolted cross member of bogie**

1. Remove the pull/push rod from the bogie.
2. Remove the cross member.

### **Fitting bolted cross member of bogie**

1. Remove the loosened bolts.  
Replace both the bolts and the nuts.
2. Fit the new cross member.
3. Tighten the attachment bolts to the specified tightening torque. See "Technical data".
4. Fit the pull/push rod.

## 7. ALIGNING

### 7.1 ALIGNING STEERING SYSTEM

#### General

1. Use reliable alignment equipment that can preferably be calibrated for any measurement.
2. Make sure the semi-trailer is on a flat surface.
3. Drive the semi-trailer in a straight line to the alignment site.
4. Check whether the markings on the coupling platform are aligned. Otherwise align the markings using the prime mover.

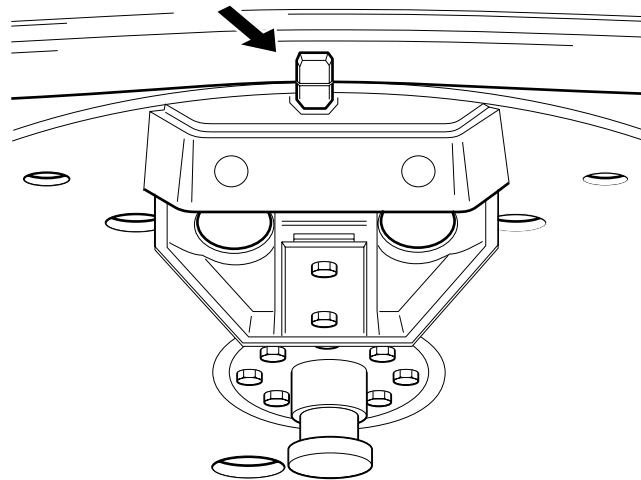

270 010

#### Checking alignment

1. Lift the semi-trailer's steerable axle.
2. Fit the alignment equipment onto the steerable axle.
3. Check the axle position.

#### Adjusting alignment

1. Check the system for damage.
2. Remove the two bolts securing the adjusting plates. Loosen the two other bolts and remove the adjusting plates. Keep the adjusting plates together.
3. Set the length of the pull/push rod.
4. Check the axle position again.

**Setting pull/push rod**

1. Place the semi-trailer's steering gear precisely in the straight-ahead position.
2. Loosen the four bolts (2) in the coupling piece between which the adjusting plates (1) are located.

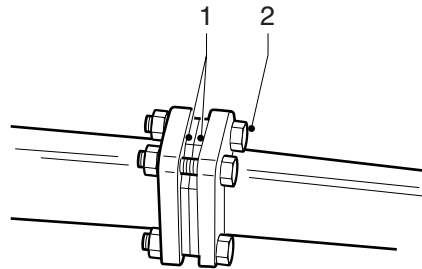

270 030

3. Remove the two bolts enclosing the adjusting plates (1).
4. Remove the adjusting plates (1).
5. Place the semi-trailer's steerable axle in the straight-ahead position using alignment equipment.
6. Measure the distance between the two coupling pieces.
7. Put together a packet of adjusting plates (1) with the same dimensions as the distance between the two coupling plates.
8. Fit the adjusting plates (1) and the two removed bolts (2). Tighten the bolts (2) to the specified tightening torque. See "Technical data".
9. Check the alignment.

## **8. PARTS LIST**

### **8.1 ORDERING PARTS**

Parts can be ordered using the part number shown.

Parts for which no part number is shown can be ordered by specifying the part description and the serial number of the steering system. The serial number is shown on the type plate.

See the Tridec parts price list for prices and terms and conditions of delivery.

**8.2 COUPLING PLATFORM, CAST VERSION**

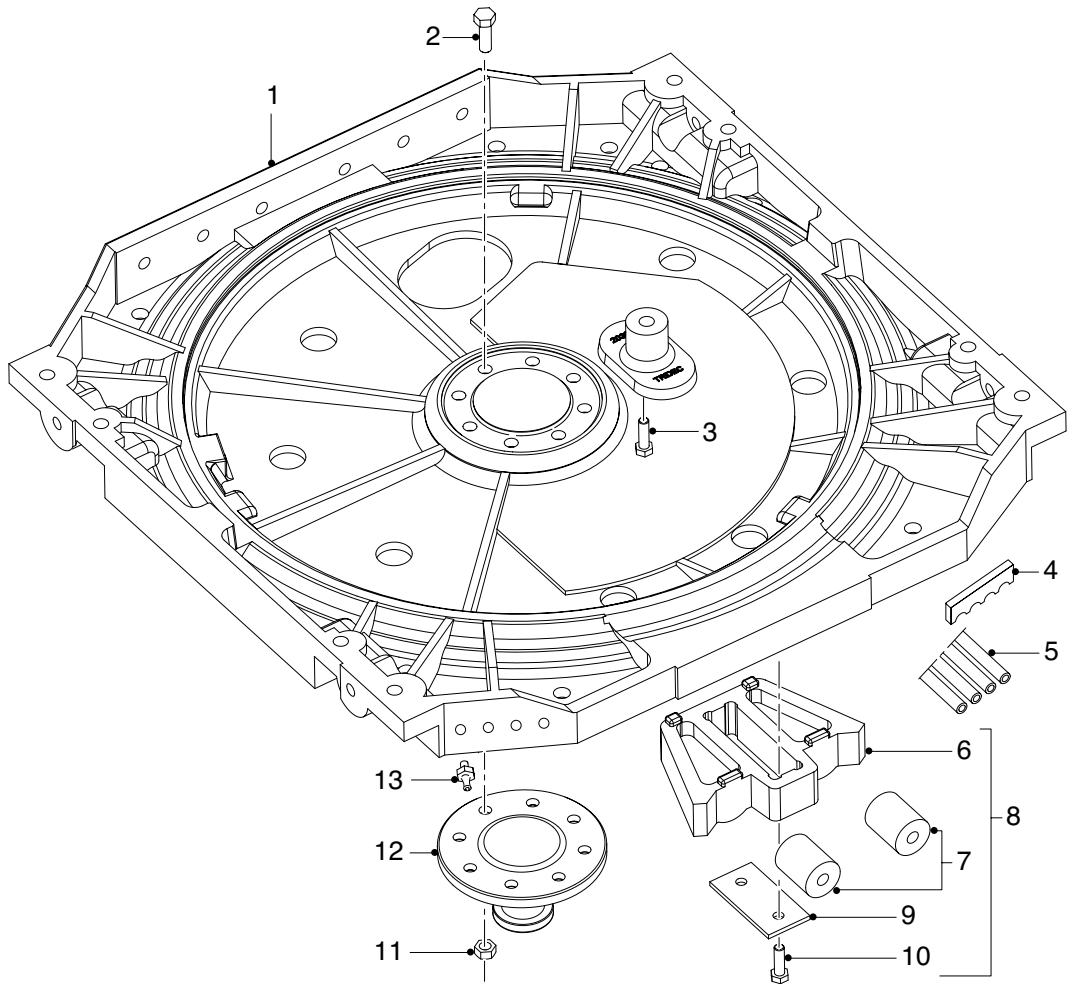

270 091



Position number	Order number	Description	Number
1	See *	Coupling platform	1
2	See *	Bolt	8
3	310016	Bolt	1
4	310799	clip	4
5	310093	Lubrication pipe 1 metre	6 metres
6	202682	Steering wedge	1
7	201353	Steering wedge rubber	2
8	320003	Steering wedge repair set	1
9	202686	Lock plate	1
10	310450	Bolt	2
11	See *	Lock nut	8
12	See *	King pin	1
13	310082	Lubricating nipple	4

\* When ordering this part, quote the part description and the serial number of the steering system.

8.3 COUPLING PLATFORM, WELDED VERSION

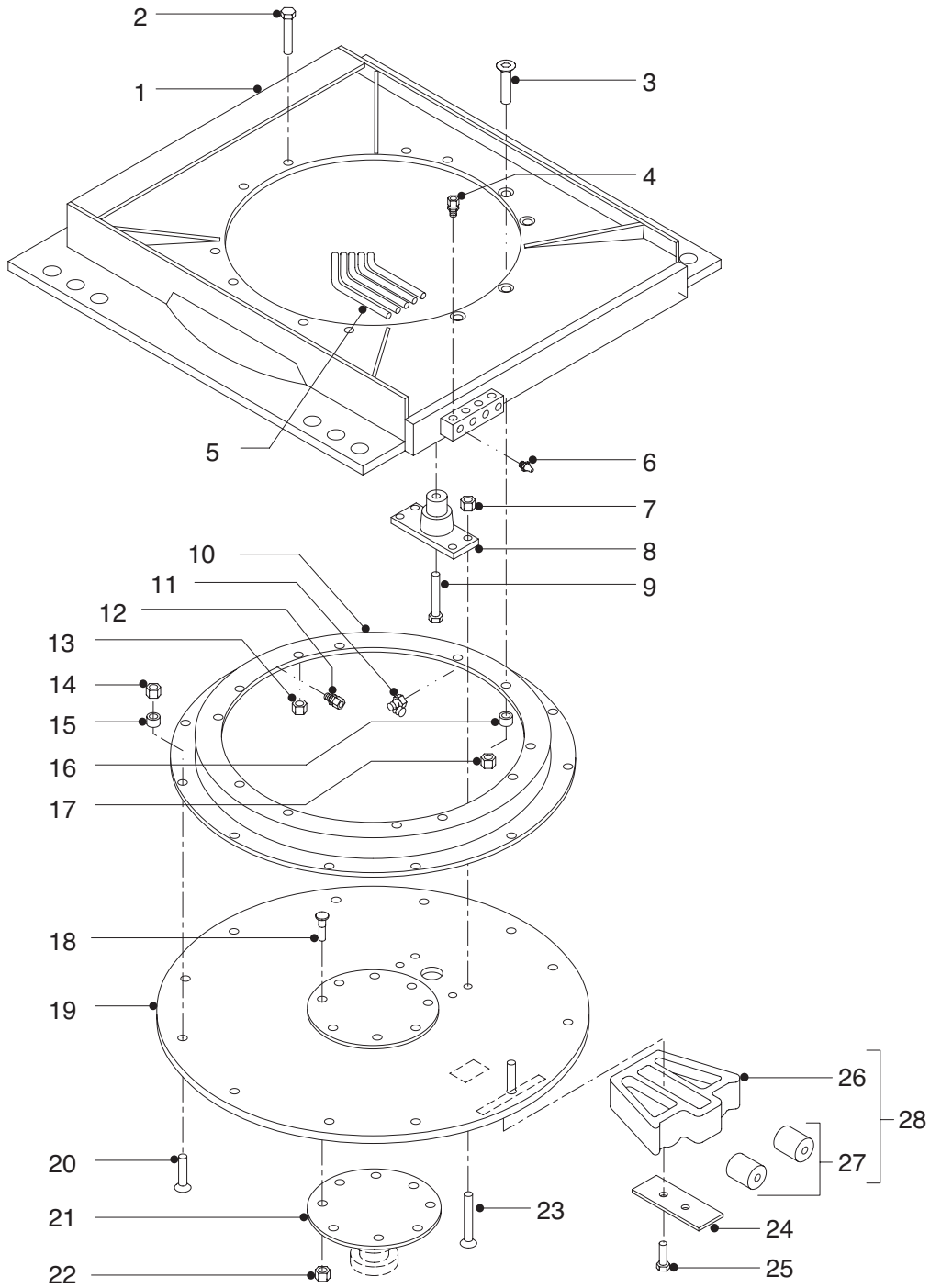

270001

Position number	Order number	Description	Number
1	See *	Coupling platform	1
2	310021	Bolt	8
3	310297	Countersunk bolt	4
4	310087	Adapter nipple	4
5	310093	Lubrication pipe 1 metre	4 metres
6	310082	Lubricating nipple	8
7	310039	Lock nut	4
8	See *	Bearing journal	1
9	310334	Central bolt	1
10	310231	Turntable	1
11	310088	Lubrication coupling at right angles	3
12	310087	Lubrication coupling	1
13	310026	Lock nut	8
14	310025	Lock nut	12
15	201198	Spacing bush	12
16	201198	Spacing bush	4
17	310025	Lock nut	4
18	See *	Bolt	8
19	See *	Turntable plate	1
20	310297	Countersunk bolt	11
21	See *	King pin	1
22	See *	Lock nut	8
23	310037	Countersunk bolt	4
24	202686	Lock plate	1
25	310450	Bolt	2
26	202682	Steering wedge	1
27	201353	Steering wedge rubber	2
28	320003	Steering wedge repair set	1

\* When ordering this part, quote the part description and the serial number of the steering system.

8.4 PULL/PUSH ROD

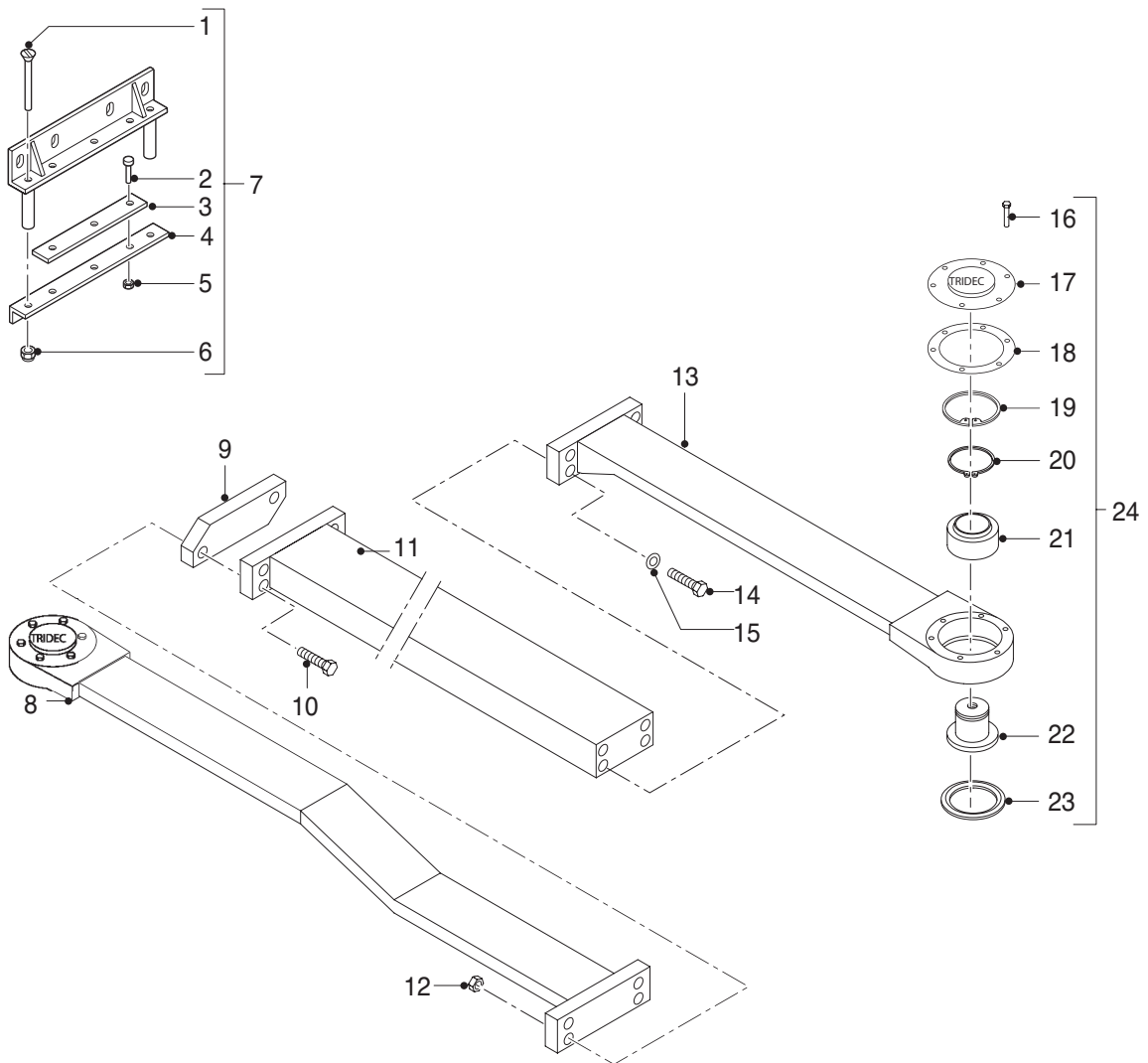

270004

Position number	Order number	Description	Number
1	310487	Bolt	2
2	310007	Countersunk bolt	6
3	210047	Glide strip	2
4	See *	Angle section	1
5	310009	Lock nut	6
6	310503	Lock nut	2
7	See *	Rod guide assembly	3
8	See *	Pull/push rod front part	1
9	210046	Set of adjusting plates	1
10	310035	Bolt	4
11	See *	Pull/push rod middle part	1
12	310040	Lock nut	4
13	See *	Pull/push rod end part	1
14	310031	Bolt	4
15	310043	Spring washer	4
16	310006	Bolt	6
17	201658	Cover	1
18	310338	Gasket	1
19	310336	Circlip	1
20	310335	Circlip	1
21	310147	Bearing	1
22	201630	Bearing bush	1
23	320001	Seal	1
24	320002	Bearing head repair set	2

\*When ordering this part, quote the part description and the serial number of the steering system.

8.5 BOGIE WITH BOLTED BEARING JOURNAL

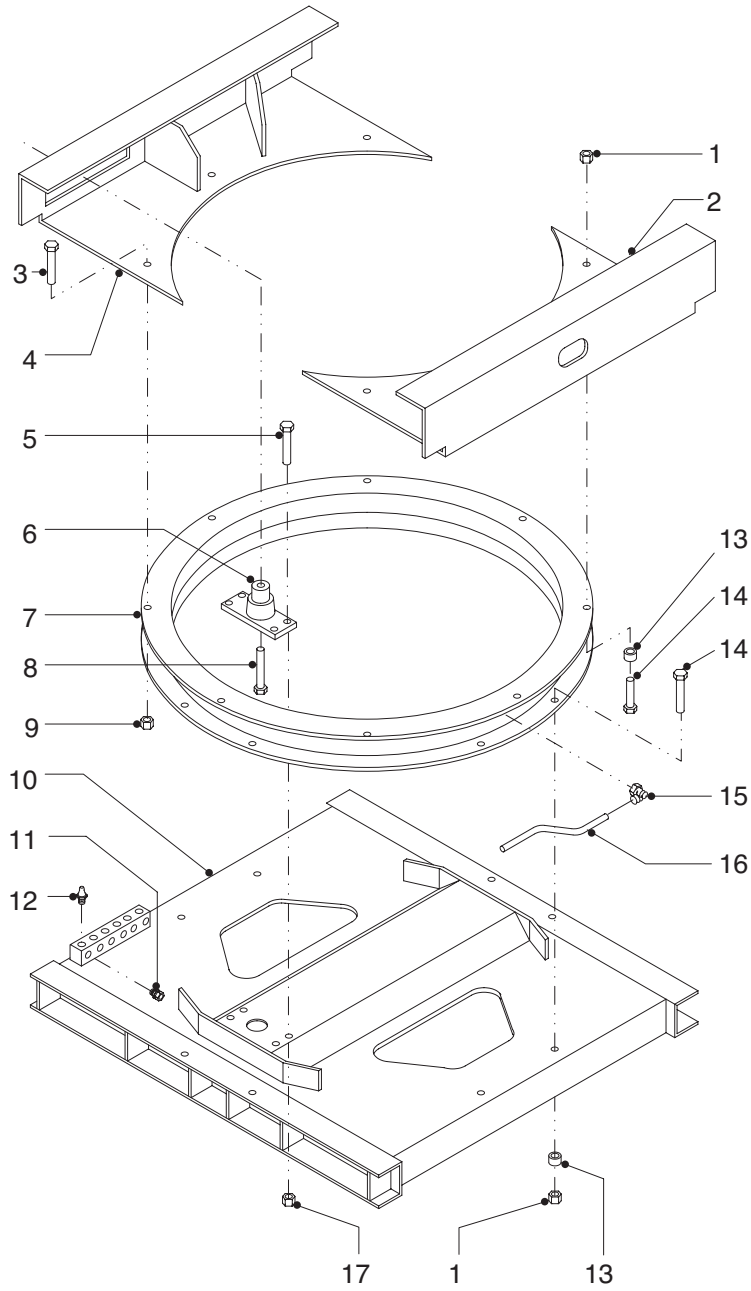

270 092

<b>Position number</b>	<b>Order number</b>	<b>Description</b>	<b>Number</b>
1	310026	Lock nut	15
2	See *	Rear cross member	1
3	310020	Hexagon-head bolt	1
4	See *	Front cross member	1
5	310035	Bolt	4
6	201632	Bearing journal	1
7	310185	Turntable, 1100 mm version	1
7	310186	Turntable, 1200 mm version	1
8	310334	Central bolt	1
9	310026	Lock nut	1
10	See *	Bogie frame	1
11	310087	Adapter nipple	6
12	310082	Lubricating nipple	12
13	201198	Ring	15
14	310021	Bolt	15
15	310088	Lubrication coupling	6
16	310093	Lubrication pipe 1 metre	6 metres
17	310040	Lock nut	4

\* When ordering this part, quote the part description and the serial number of the steering system.

**8.6 BOGIE WITH WELDED BEARING JOURNAL.**

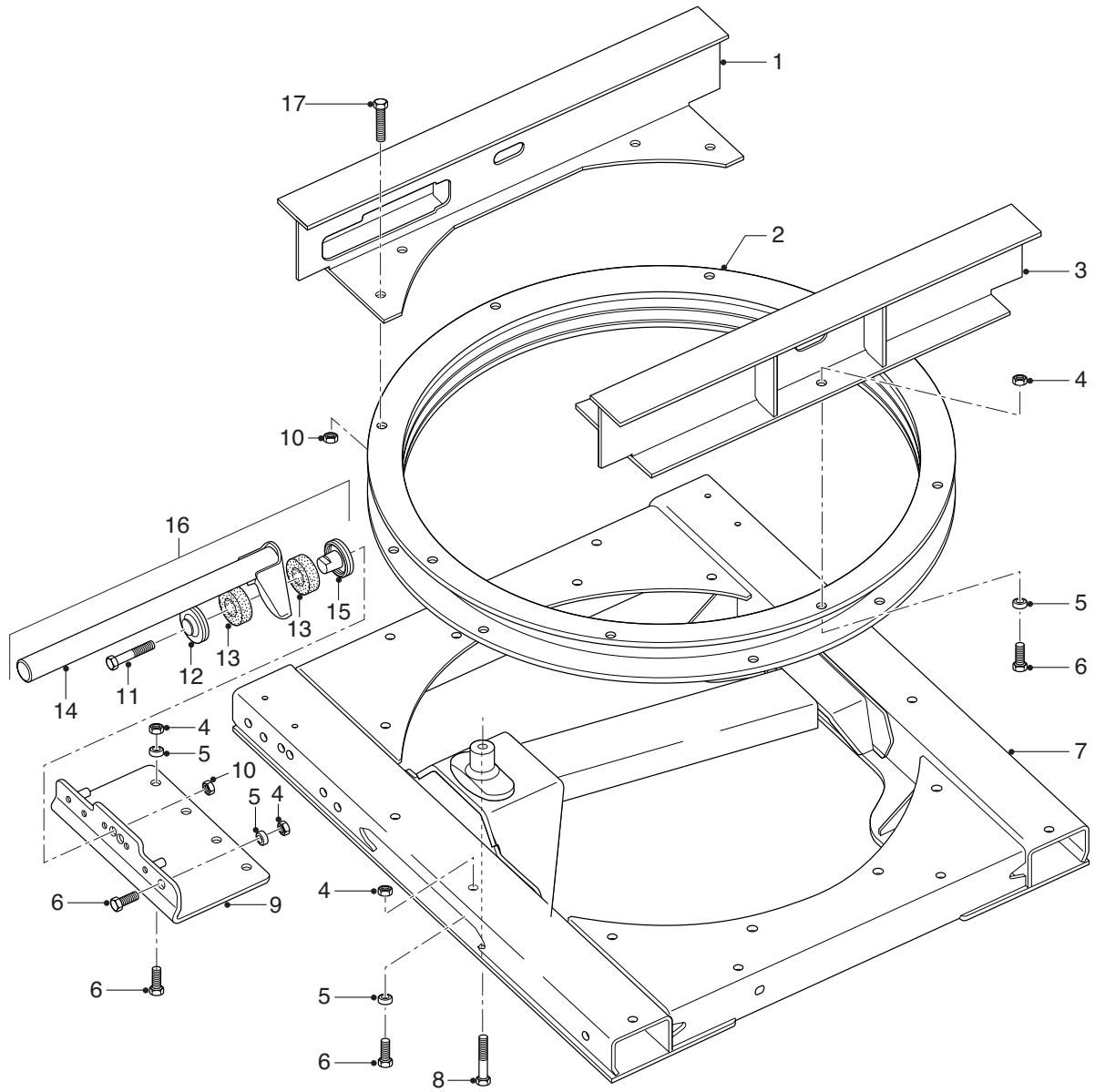

270 093



<b>Position number</b>	<b>Order number</b>	<b>Description</b>	<b>Number</b>
1	See *	Cross member	1
2	310185	Turntable, 1100 version	1
2	310186	Turntable, 1200 version	1
3	See *	Cross member	1
4	310026	Lock nut	40
5	201198	Spacing bush	40
6	310021	Bolt	40
7	See *	Bogie frame	1
8	310967	Bolt	1
9	205155	Mounting plate	2
10	310026	Lock nut	6
11	310505	Bolt	4
12	205647	Mudguard support	4
13	205417	Mudguard rubber	8
14	206040	Mudguard support, 1100 version	4
14	206041	Mudguard support, 1200 version	4
15	205646	Mudguard support	4
16	206394 206395 206425	Mudguard support L=455 L=455 L=770	4 4 4
17	310020	Bolt	2

\* When ordering this part, quote the part description and the serial number of the steering system.

**8.7 BOGIE WITH BOLTED CROSS MEMBER**

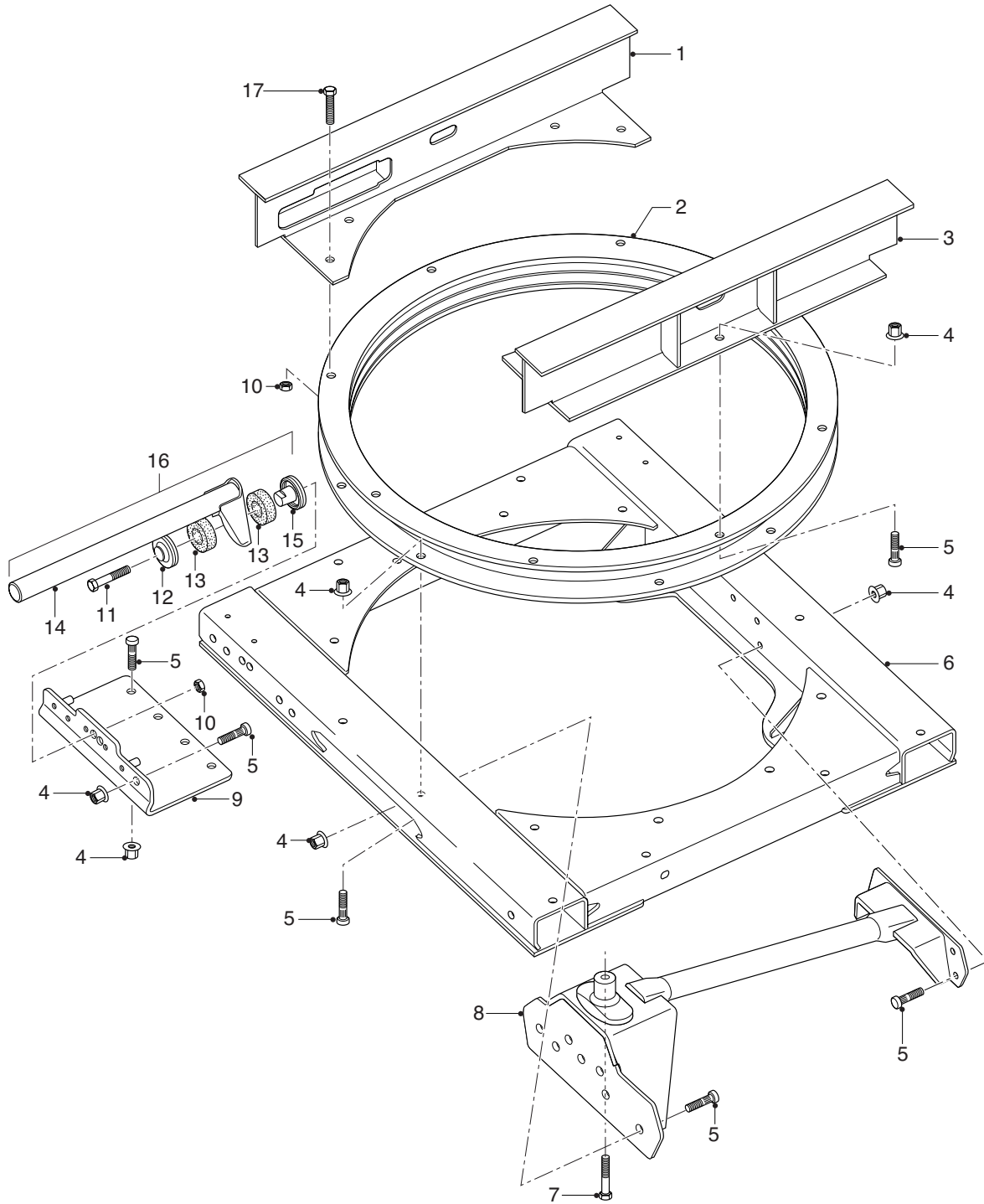

270 094

<b>Position number</b>	<b>Order number</b>	<b>Description</b>	<b>Number</b>
1	See *	Cross member	1
2	310185	Turntable, 1100 version	1
2	310186	Turntable, 1200 version	1
3	See *	Cross member	1
4	206038	nut	54
5	206037	Bolt	54
6	See *	Bogie frame	1
7	310967	Bolt	1
8	205741	Cross member	1
9	205155	Mounting plate	2
10	310026	Lock nut	6
11	310505	Bolt	4
12	205647	Mudguard support	4
13	205417	Mudguard rubber	8
14	206040	Mudguard support, 1100 version	4
14	206041	Mudguard support, 1200 version	4
15	205646	Mudguard support	4
16	206394 206395 206425	Mudguard support L=455 L=455 L=770	4 4 4
17	310020	Bolt	2

\* When ordering this part, quote the part description and the serial number of the steering system.

